



Manutenzione: Le naturali variazioni di colore e di venatura sono caratteristiche del legno.
Per mantenere nel tempo la bellezza naturale del legno massello del vostro cavalletto si consiglia di utilizzare olio di lino
crudo da stendere con un panno morbido.

*Maintenance: Variations in colour and grain are a natural characteristic of the timber.
Maintain your easel with an occasional application of raw linseed oil using a soft cloth.*

art. CS-100 BIS KIT

Dim.: 54x48 cm (22"x19")

Height: 175/245 cm high.
(69"/96")

Max canvas height: up to 135cm
high (53").

Weight: 8 Kg (18 lbs)

Cavalletto da studio in legno, doppia mensola portaoggetti. Rialzabile a cremagliera. In pregiato legno di faggio, finitura oliato. Per piccoli studi di pittura o quando lo spazio è prezioso, questo cavalletto da studio si ripiega completamente piatto con un solo facile movimento. Amato dalle scuole di pittura e istituzioni per il design poco voluminoso, permette allo studente di lavorare comodamente anche in esigue sale di pittura. Stabile, affidabile, con sistema a cremagliera per la regolazione in altezza della mensola inferiore. Il cavalletto è predisposto per l'applicazione delle mensole ET-1 ET-2 e delle cassette portacolori CA-4 e CA-6. Queste forniscono un ulteriore piano di appoggio e/o contenitore per pennelli colori o altro. Si applicano con semplice sistema ad incastro senza viti. Disponibile anche in kit di montaggio.

Studio easel, it features an utility shelf for storing supplies, adjustable by ratchet control. For small studios or when space is at a premium this H frame easel is one of the few in the market that can fold completely flat in one motion. Loved by schools and institutions because of the folding feature and narrow design it allows to students to be fit comfortably in smaller painting rooms. Stable, reliable, with ratchet adjustment system for lifting the bottom canvas tray and securing it in place. Intended for additional easel trays ET-1, ET-2 and hanging colours boxes CA-4, CA-6 for further storage of brushes, colours etc. To be applied by simple joint system without use of any screws. Available assembled or in kit format.



Handmade Italian Easels

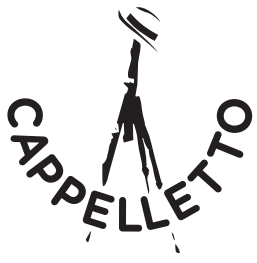

Handmade Italian Easels

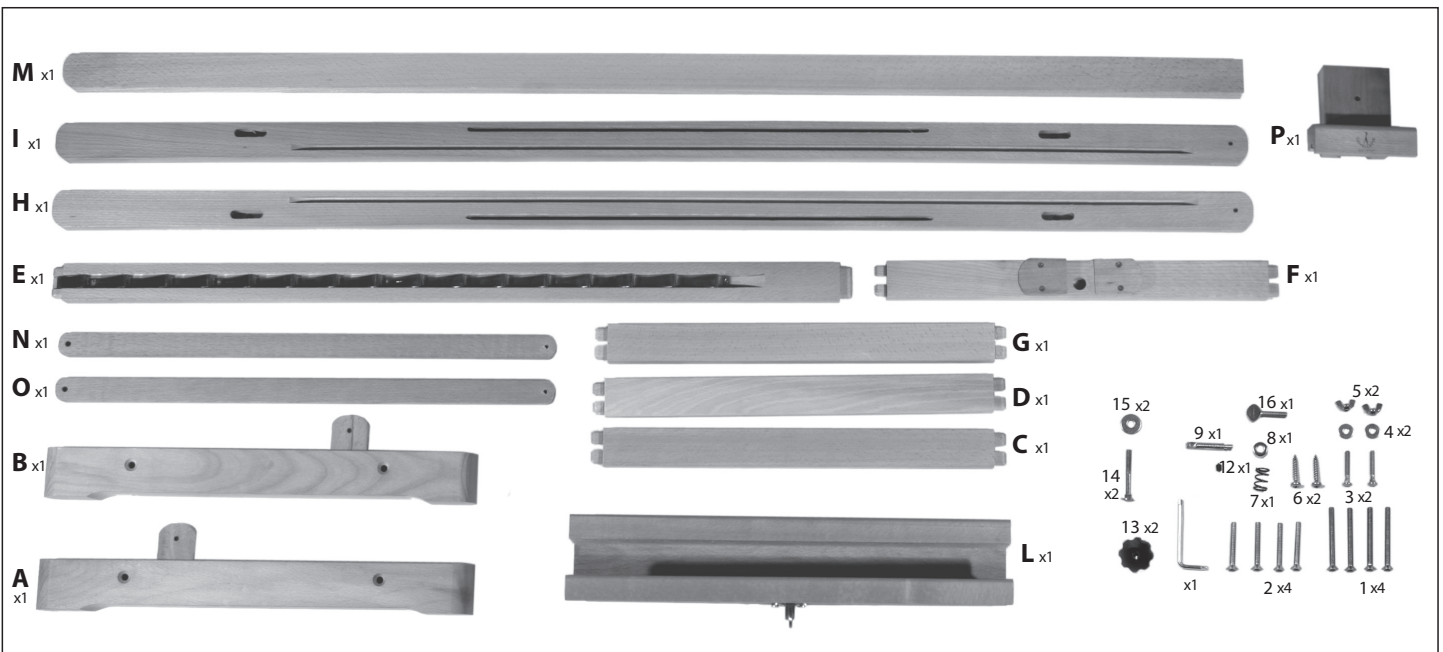
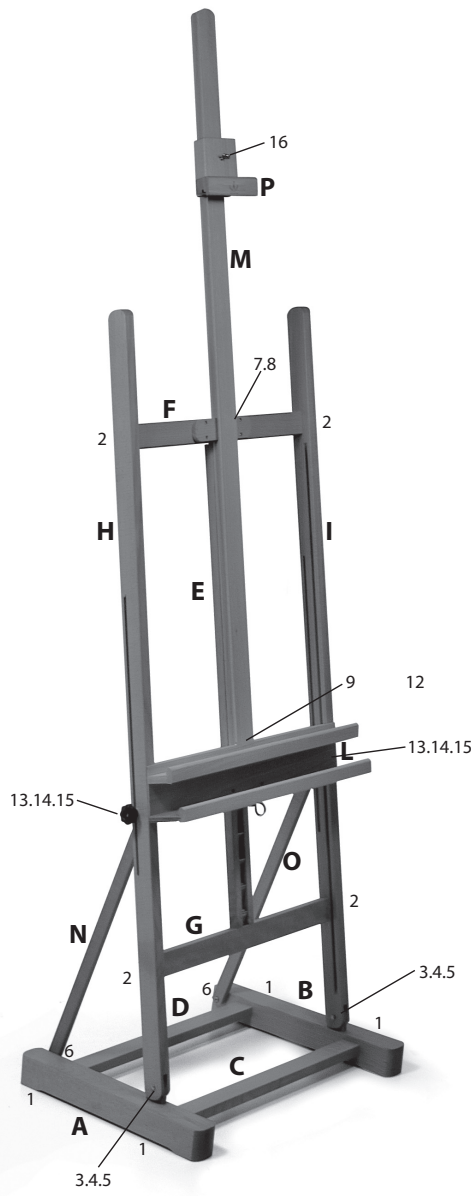

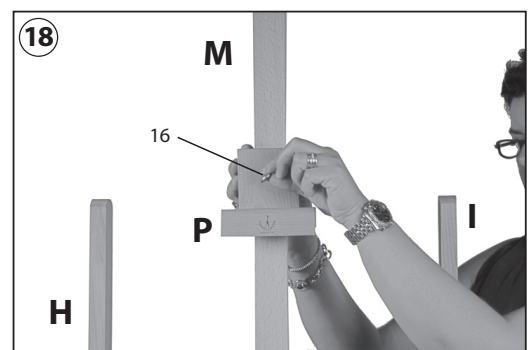
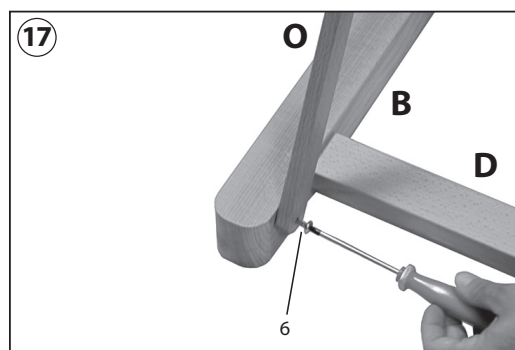
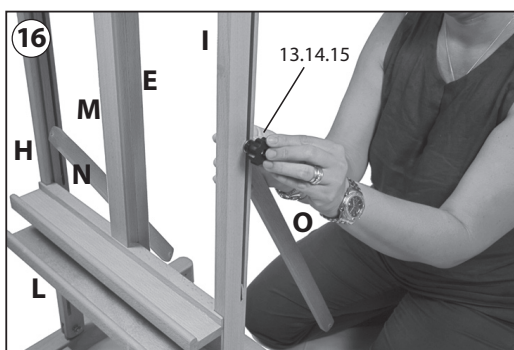
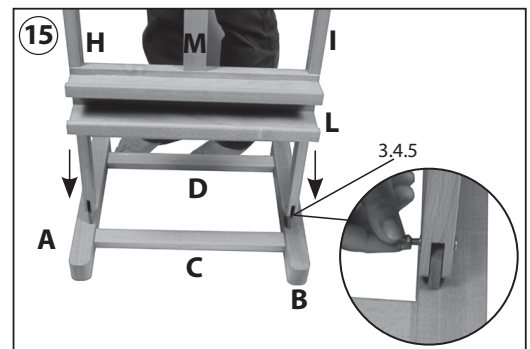
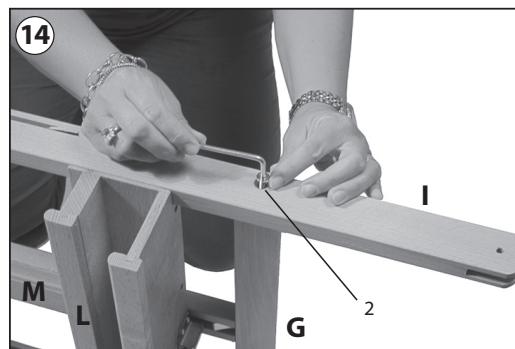
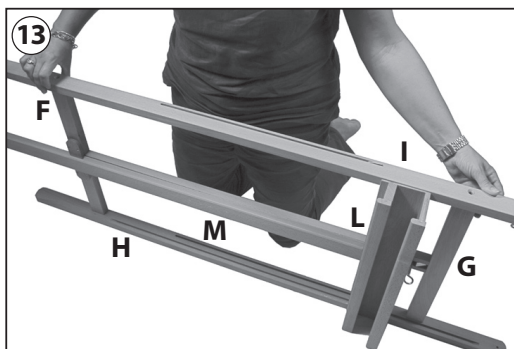
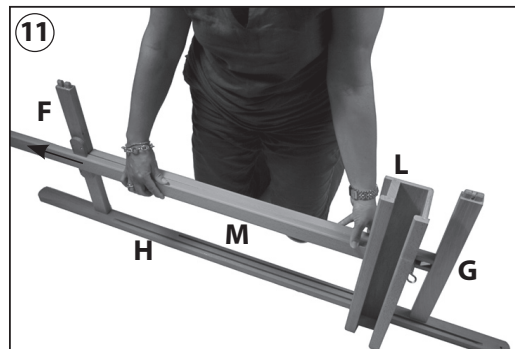
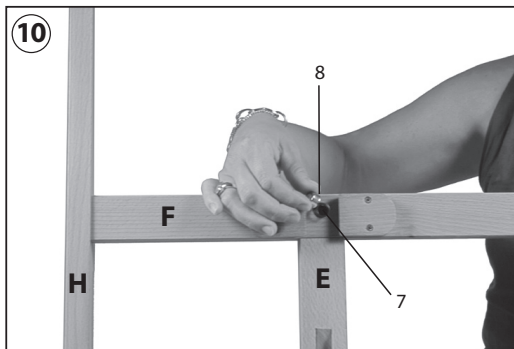
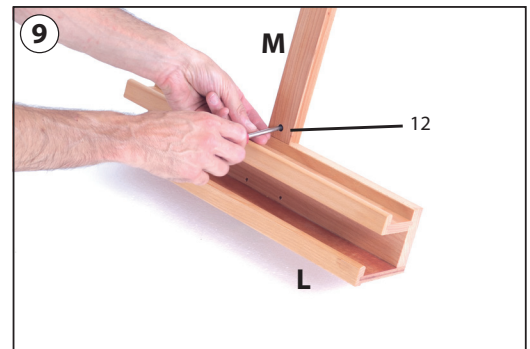
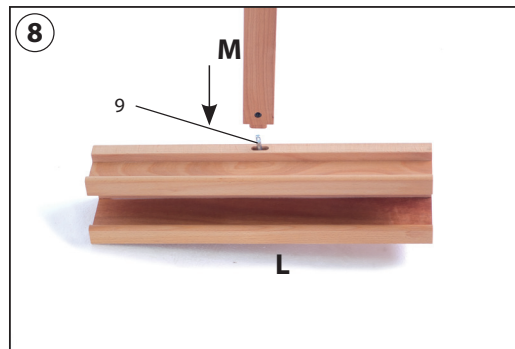
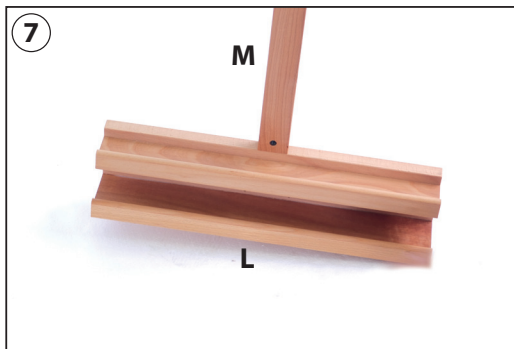
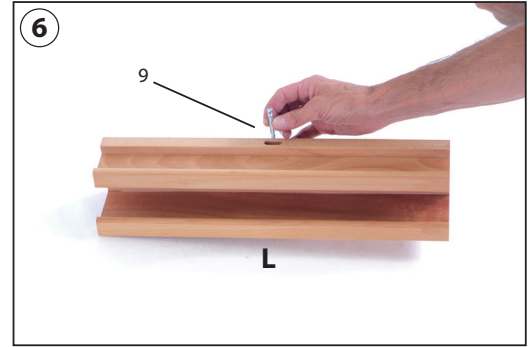
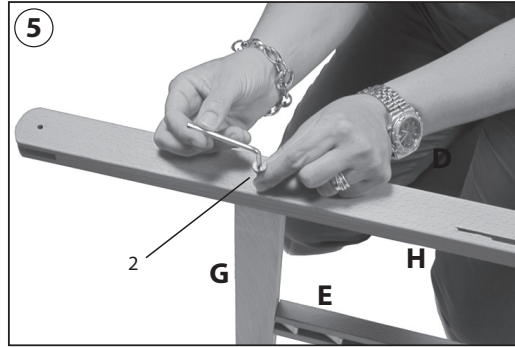
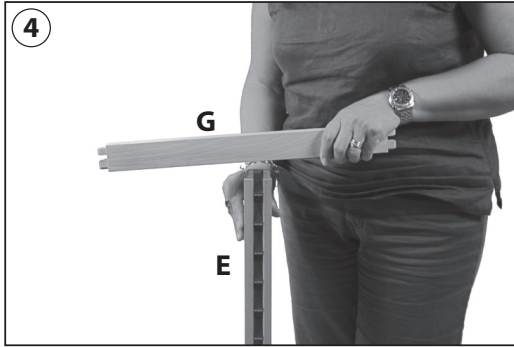
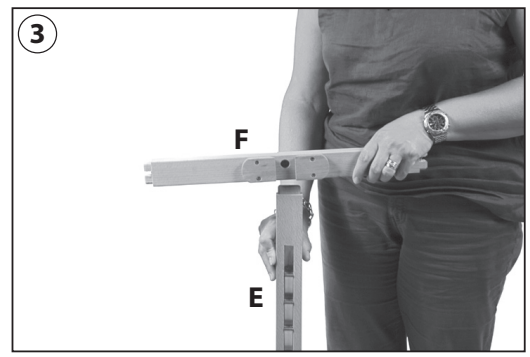
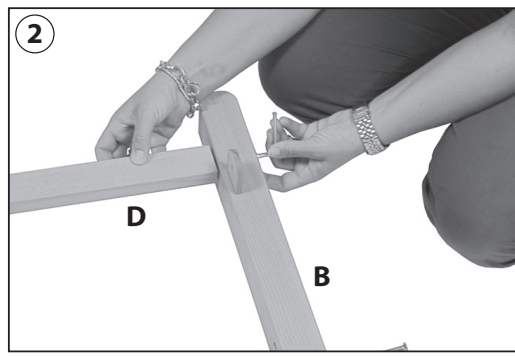
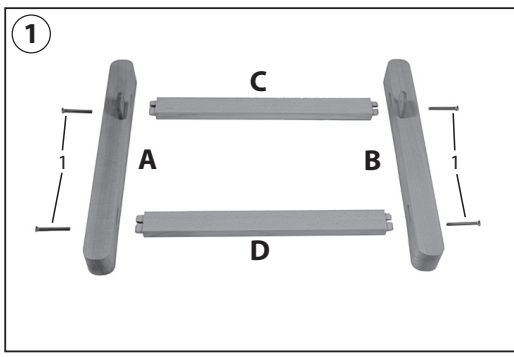



Handmade Italian Easels

Cappelletto s.r.l.
Cavalletti per belle arti e affini
Via Marghera, 9
31033 Castelfranco Veneto (TV) Italy
tel. +39 0423 493316
fax +39 0423 744962
e-mail: info@cappellettoitalia.it
www.cappellettoitalia.it